

Dhyana 9KTDI

The Dhyana 9KTDI camera is designed for speeding up light-limited acquisition with TDI technology and BSI-CMOS to offer the first scientific grade TDI device.



Key Features

Benefits

200-1100 nm	Wide spectral response across UV / Visible / NIR.
82% Peak QE	High photon collection efficiency for lower illumination intensity.
256 stages TDI	More TDI stages deliver higher SNR. ^[1]
510 kHz @ 9K	> 50X faster than the back-illuminated TDI-CCD cameras. ^[2]
Air & Liquid Cooling	Maintains low dark noise, minimizes vibration, and aids thermal stability.

Typical Applications

- Wafer Inspection
- FPD Inspection
- Fluorescence Detection

Noted Examples

[1] More TDI stages deliver higher SNR.

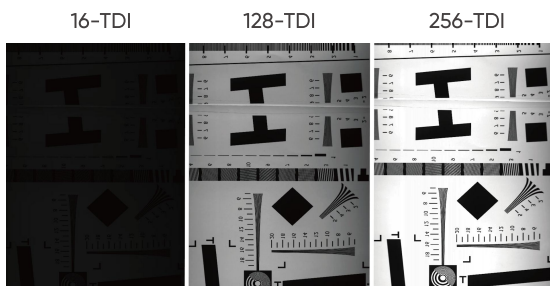

[2] > 50X faster than CCD technology.

	Mpixel / s
Dhyana 9KTDI 9K @ 510 kHz	4590
BSI TDI-CCD 2K @ 50 kHz	100

Quantum Efficiency

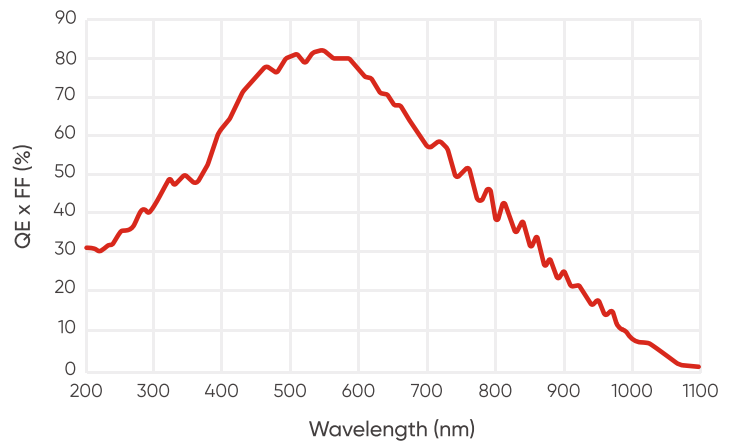

Dimensions (Unit: mm)

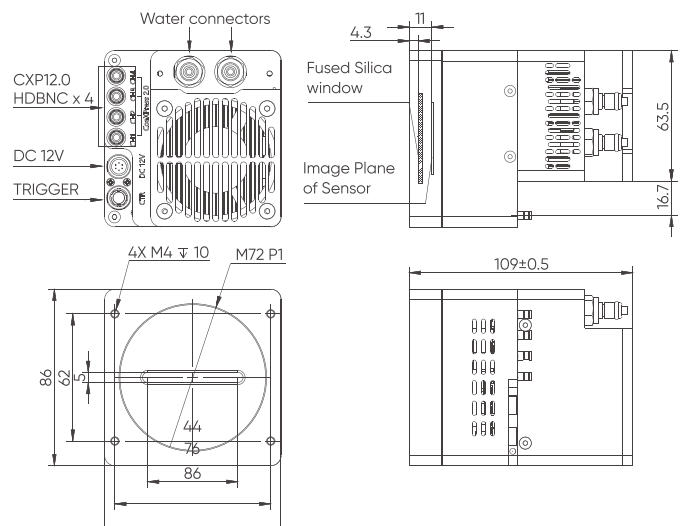

Specifications

High Speed TDI sCMOS Camera

www.tucsen.com

Model	Dhyana 9KTDI
Sensor Type	BSI sCMOS TDI
Sensor Model	Gpixel GLT5009BSI
QE	38 % @ 266 nm, 51% @ 355 nm, 82 % @ 550 nm, 38 % @ 800 nm
Color/Mono	Mono
Array Diagonal	45.4 mm
Effective Area	45.36 mm x 1.28 mm
Resolution	9072 (H) x 256 (V)
Pixel Size	5 μm x 5 μm
Operation Mode	TDI, Area
TDI Stage	4, 8, 16, 32, 64, 96, 128, 160, 192, 224, 240, 248, 252, 256
Scan Direction	Forward, Reverse, Trigger Control
CTE	≥ 0.99993
Data Bit Depth	12 bit, 10 bit, 8 bit
Full-Well Capacity	Typ. : 15.5 ke ⁻ @ 12 bit, 14 ke ⁻ @ 10 bit
Dynamic Range	Typ. : 68.7 dB @ 12 bit, 63.6 dB @ 10 bit
Max. Line Rate	299 kHz @ 12 bit, 345 kHz @ 10 bit, 510 kHz @ 8 bit
Readout Noise	Typ. : 7.2 e ⁻ @ 12 bit, 11.4 e ⁻ @ 10 bit
DSNU	Typ. : 1.5 e ⁻ @ 12 bit, 3.5 e ⁻ @ 10 bit
PRNU	Typ. : 0.30 %
Cooling Method	Air, Liquid, Cooling speed 5 °C / min
Max. Cooling	35 °C below ambient (Liquid)
Binning	1 x 1, 2 x 2, 4 x 4, 8 x 8
ROI	Support
Trigger Mode	Trigger Input, Scan Direction Input
Output Trigger Signals	Strobe out
Trigger Interface	Hirose, HR10A-7R-4S
Timestamp Accuracy	8 ns
Analog Gain	x2 ~ x8, Step 0.5
Digital Gain	x0.5 ~ x10, Step 1
Optical Interface	M72 / Customization
Data Interface	CoaxPress 2.0 (CXP-12)
Power Supply	12 V / 8 A
Power Consumption	< 60 W
Dimensions	86 mm x 86 mm x 109 mm
Weight	1100 g
Software	SamplePro
SDK	C, C++, C#, Python
Operating System	Windows, Linux
Operating Environment	Working: Temp. 0~40 °C, HUM 0~85 °C, Storage: Temp. 0~60 °C, HUM 0~90%