

NEW!

INTEGRATED 3D LASER PROFILER

- High integrated
- High-speed and stability
- Adapt to various scenarios





About SinceVision

Since its establishment, SinceVision has focused on 3D industrial sensors, launching products such as 3D Laser Profile, Spectral Confocal Displacement Sensor, Laser Displacement Sensors, and Through-Beam Edge Sensor. In 2021, SinceVision expanded into research and development and the defense market, introducing High-Speed Cameras and multiple product lines, with dozens of series now in mass production. Mass-produced products of Sincevision have successfully broken foreign monopolies, establishing us as a leader in domestic brands. Furthermore, our mature products, particularly 3D Laser Profile, have achieved some world-leading performance parameters, gradually becoming a new benchmark in the industry.

Today, SinceVision is increasingly recognized in automation. We have served hundreds of customers, with our products reaching major domestic and international brands in consumer electronics, lithium batteries, and photovoltaics. We are tirelessly promoting refined product solutions tailored to specific fields, empowering various industries with our products and services. From semiconductors and panels to automotive and rail transit, and from plastics and films to food and textiles, we contribute to cost reduction and efficiency enhancement across multiple sectors.

As labor costs rise and product quality upgrades, the future of industrial automation is unstoppable. With years of experience in 3D industrial sensor research and development, SinceVision has developed a comprehensive R&D platform encompassing optics, mechanics, electronics, and software, along with a mature production control system. In the future, we will relentlessly improve our R&D platform and build a world-class industrial product development team. With the craftsmanship of SinceVision's people, we will continue to tackle high-end sensors, ensuring that Chinese automation has reliable domestic products and trusted national brands.

In order to provide our customers with fast and convenient services, we have set up many offices in China and overseas.

China

Shenzhen, Suzhou (Kunshan), Shanghai, Wuxi, Beijing, Chengdu, Ningde, Taiwan, Wuhan, Xi'an, Hefei, Dongguan

Overseas

South Korea, Vietnam, Thailand, Malaysia, Singapore

MILESTONE

2014

April
Shenzhen SinceVision Technology Co.,Ltd. was officially established

2016

March
Released the first generation of 3D Laser Profiler the SR7000 series.

2017

March
Obtained the titles of "National High-tech Enterprise" and "Shenzhen Industrial Stable Growth Enterprise."

2018

March
Released 3D laser profiler the SR8000 series

March
SinceVision completed Round A financing

2021

March
Released 3D Laser Profiler the SR9000 series

September
SinceVision completed Round B financing

December
Released Laser Displacement Sensor - the SD series

2020

March
Released 3D Laser Profiler the SR5000 series

June
Released Spectral Confocal Displacement Sensor - the SC series

December
Established offices in Chengdu and Beijing, expanding services to the Southwest and North China regions.

2019

March
The East China office was officially established in Kunshan to serve the Yangtze River Delta region.

November
SinceVision completed Round A+ financing

December
Released Laser Displacement Sensor the SG series and the SGI series

2022

April
SinceVision completed Round B+ financing, co-led by MPC and GL Ventures. SinceVision entered the scientific research and defense markets, launching the first generation of High-Speed Camera - the SH6 series.

September
SinceVision obtained "CE Certification," "FCC Certification," "KC Certification," "Precision Certification," "ISO9001 Certification," "ISO14001 Certification," and "Social Accountability Management System Certification."

December
Released Through-Beam Edge Sensor - the SE1 series
Established offices in Dongguan, Hefei, Xi'an, and other regions, covering nationwide services.

2023

June
Released High-Speed Camera the SH3 series and Through-Beam Edge Sensor- the SE2 series

September
SinceVision completed Round C financing, led by the Advanced Manufacturing Fund managed by SDIC Fund Management Co., Ltd., with follow-on investment from GL Ventures. SinceVision was awarded the title of "National new special 'Small Giant' Enterprise."

October
Formally established the International Department, developing markets in Southeast Asia and Europe, with a service network covering the globe.

2024

February
Released 3D Laser Profiler the SRI series

March
Released white light spot photoelectric sensor - the SS1 series and Laser Displacement Sensor - the SDC series

June
Released High-Speed Camera-the SH2 series and Spectral Confocal Displacement Sensor- the SCI series



Working Principle

The optical system inside the sensor focuses the laser beam into a stable static line. The image sensor captures the laser line information projected by the laser emitter on the surface of the object, and analyzes the distance (Z-axis) and line position (X-axis) in real time. It outputs a fixed origin two-dimensional coordinate and combines it with the movement information of the measured object or the sensor to achieve accurate 3D measurement.

The development of 2D detection to 3D detection is an inevitable trend in the future.

2D (X, Y)

3D (X, Y, Z)

01

Adding height information to realize three-dimensional measurement of objects

02

More adaptable in optical environment

Only accept light with a fixed range of wavelengths.
Insensitive to light interference and ambient light changes.

No need to give a special light source

03

It is more compatible with materials with different reflectivity.

Dimension-stitching measurement of complex workpiece

04

It is more accurate, simpler and more efficient in 3D measurement.

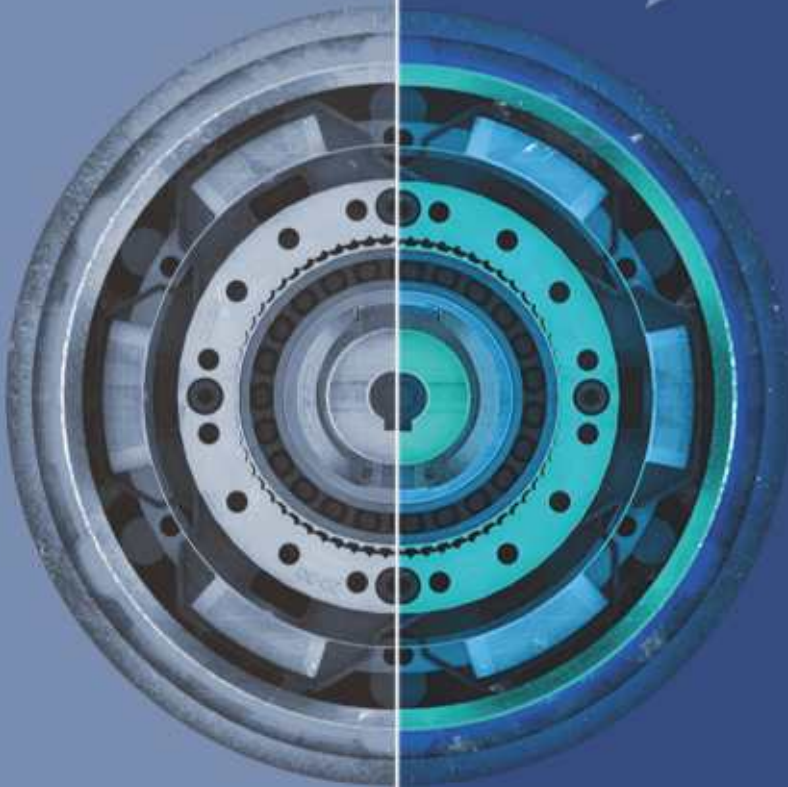

50% Installation space

Highly integrated to save more than 50% installation space.

3200 Contour points

Ultra-high linear laser resolution
Accurately restore the target shape

60kHz Sampling frequency

Ultra-high speed
Highest sampling frequency of 60kHz

30 million times bending

High flexible cable
Bending times up to 30 million

IP67 Protection level

IP67 rating provides a high level of protection against both dust and water environment





UFP processor

Equipped with Ultra-Fast processor, the customized IC has ultra-high-speed channel processing capability. Not only can it quickly read CMOS shooting data and perform high-resolution sub-pixel processing, but also output high-precision data, etc.

SSHE-CMOS

SSHE-CMOS combines high speed and high dynamic range, and is a specialized component for 3D laser profiler. For materials with different reflectivity, brightness does not need to be adjusted. It can stably measure all target objects, achieving high sensitivity and wide dynamic range. Even with extremely short exposure times (10 μ s), it can accurately measure objects with black (low reflection) or even glossy surfaces (high reflection).

Introduction to UFP Processing Function

Through ultra-high-speed sampling and output, online quality inspection during production can be achieved.

By averaging multiple high-speed sampled data, more stable measurement results can be obtained.

Through ultra-high-speed sampling processing, both height and grayscale information can be output simultaneously, with a maximum sampling speed of 192M contour points per second.

Application Cases

Mobile Phone Frame Accessory Detection

No need for multiple 3D sensors to be spliced or scanned multiple times, scanning one time by one device can obtain complete 3D data of the phone frame, which can detect the accessories inside the frame while ensuring accuracy and greatly improving detection efficiency.



Detection of Length, Width and RAngle Profile in Mobile Phone Frame

Through two 3D sensors, the inner side wall of the middle frame of the mobile phone is scanned in a 45° cross-installation manner, and at the same time, the length, width and corners in the middle frame are measured by stitching the point cloud images.

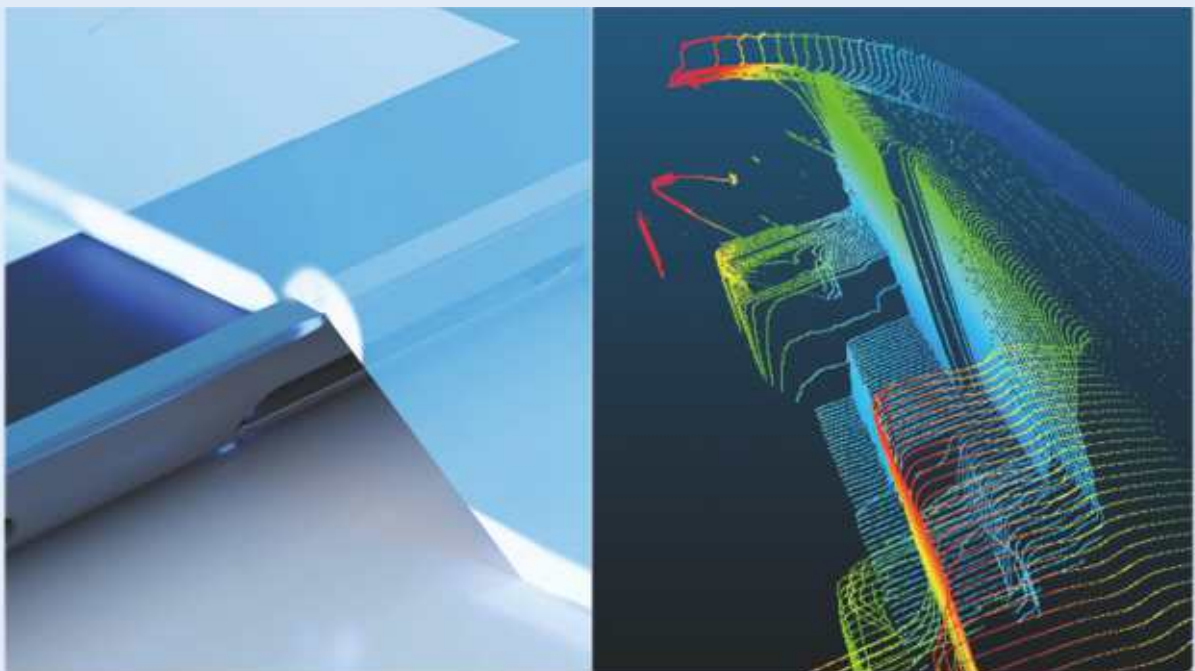

Application Cases

Glue Guiding + Glue Path Detection

Using high-precision 3D sensor, the middle frame is scanned before dispensing, and the three-dimensional coordinate information of the gluing path is accurately extracted, and the coordinate information is provided to the dispensing system to complete the dispensing guidance. After the glue coating is completed, the glue is scanned, the height and width of the glue are measured, and the coating quality is monitored. The guidance and re-inspection realized the closed-loop control of dispensing process, which greatly improved the production efficiency and product quality.

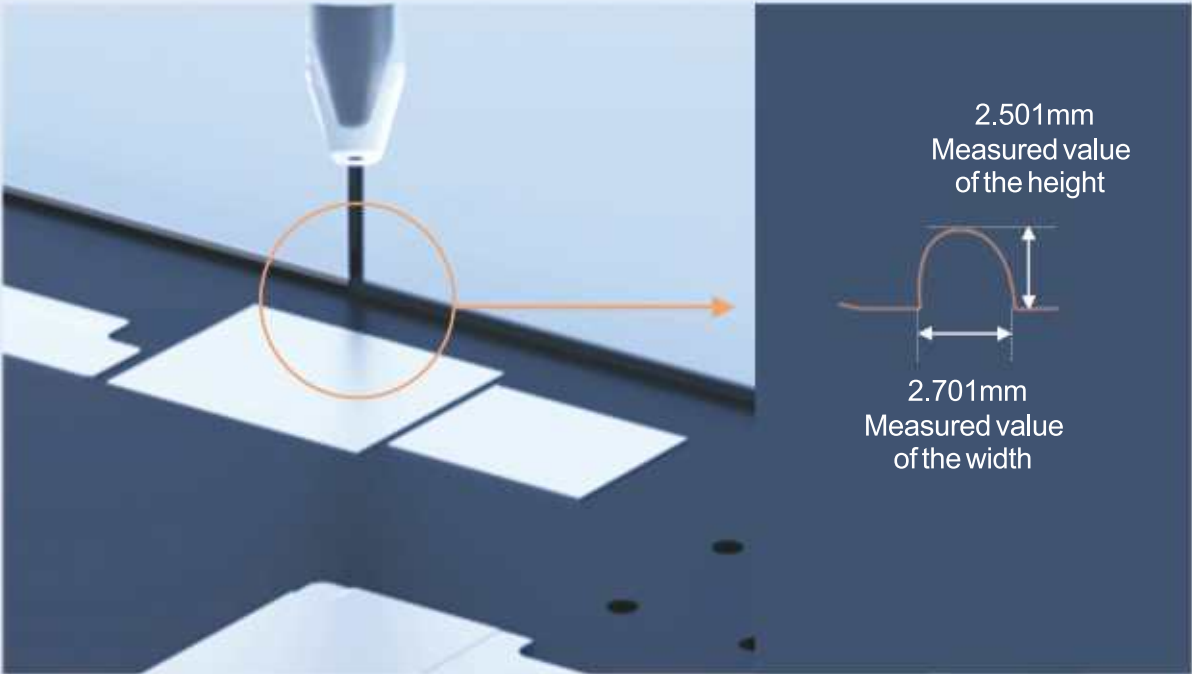

Welding Guide

In the laser welding process of non-standard workpiece, the welding robot is equipped with a 3D sensor to scan the welding groove and output the shape and position information of the groove to the welding robot in real time, so as to correct and guide the welding position, improve the welding accuracy and stability and reduce the production time.

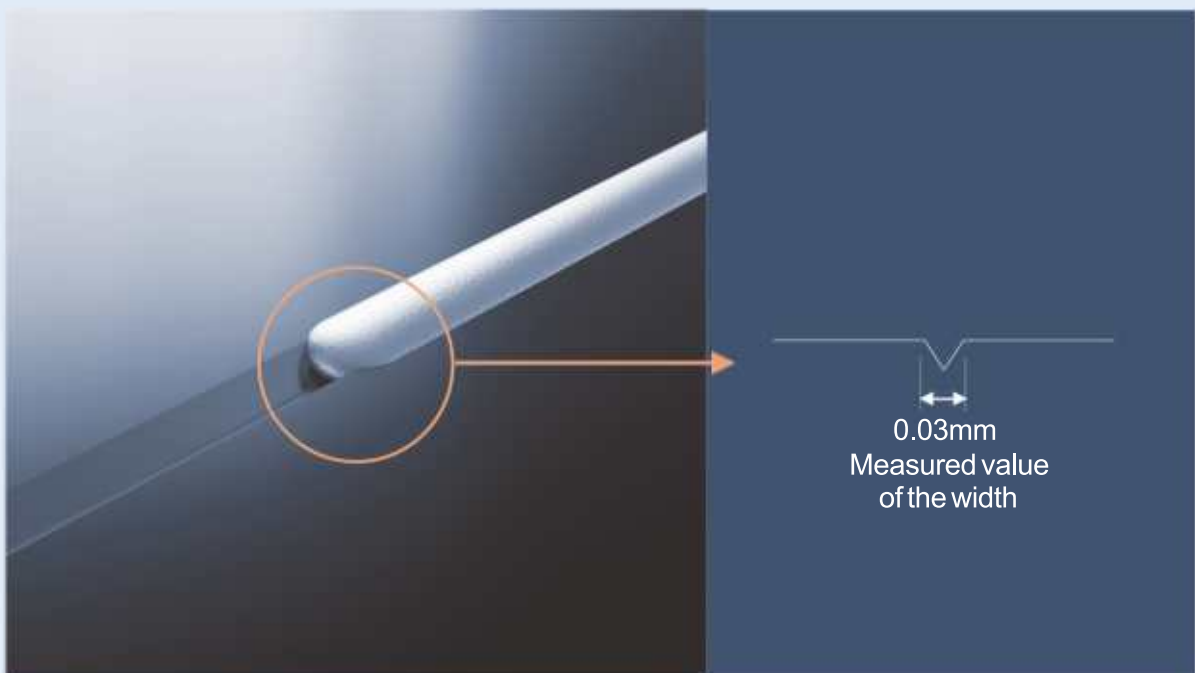

Application Cases

Welding Quality Inspection

Collect height and grayscale data through 3D sensors installed in a tilted manner as shown in the diagram. High-precision imaging can accurately detect defects such as bumps, dents, broken welds, pinholes, virtual welds, misalignment, and flanging in incoming materials. Avoiding leakage problems caused by welding quality and improving product stability and reliability.

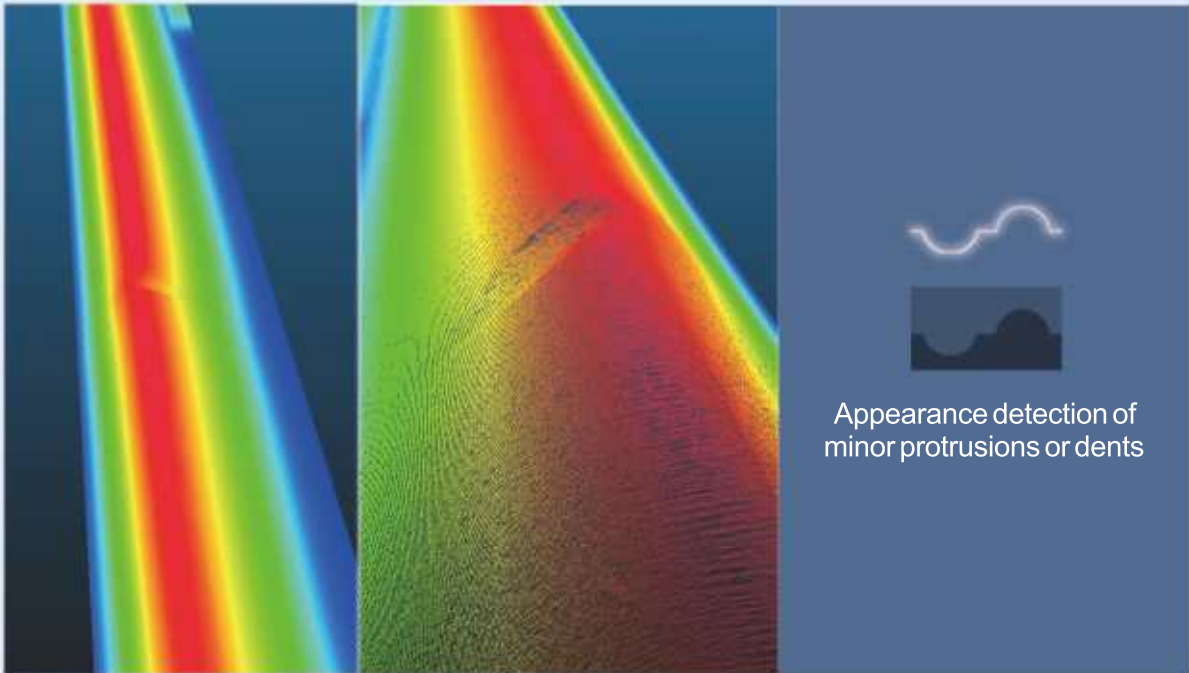
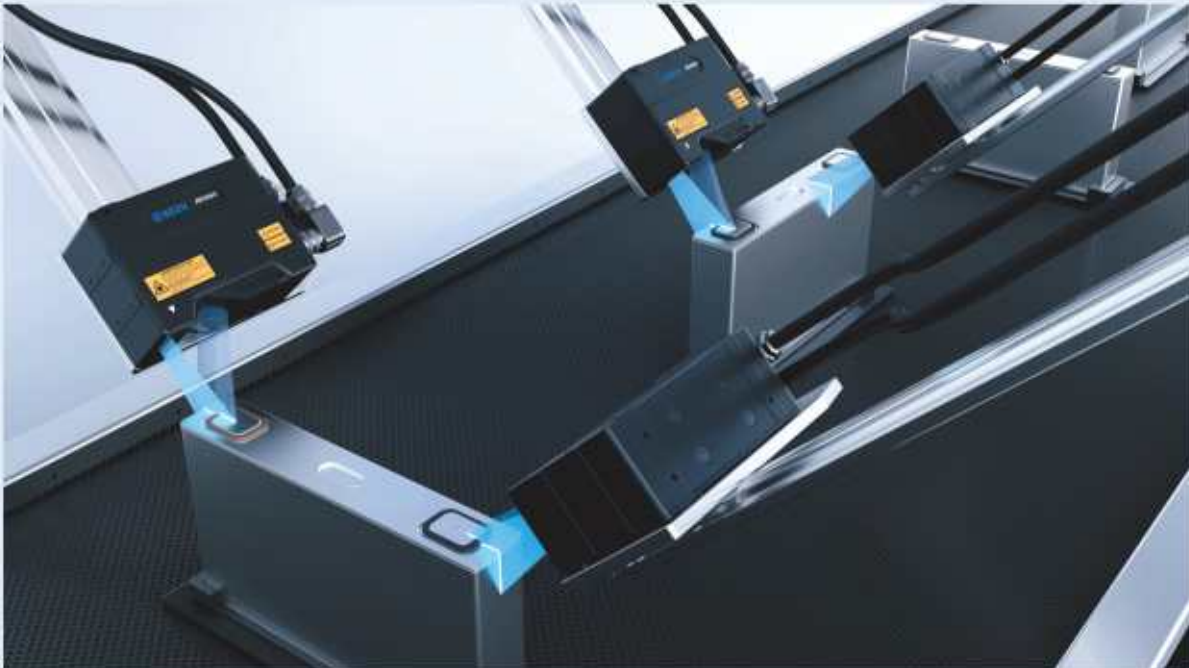

Connector Pin Detection

By using a non-contact measurement method, the top of the pin of the connector can be imaged accurately to measure the height, coplanarity, and positional accuracy of the pin.

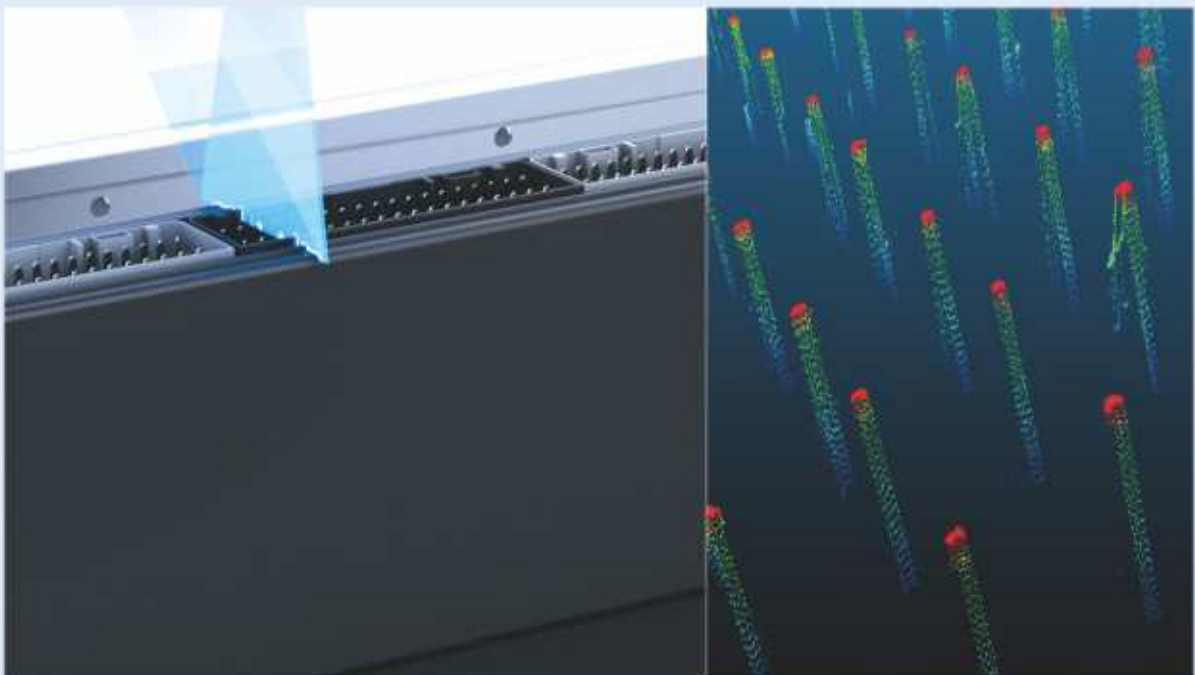

Application Cases

Quality Inspection of Soldering Balls for Motor Stator

Through the head-to-head installation of two 3D sensors, the blind area is effectively eliminated, and the defects such as insufficient wetting, missing solder, non-centered soldering and solder icicle of solder balls can be accurately detected.

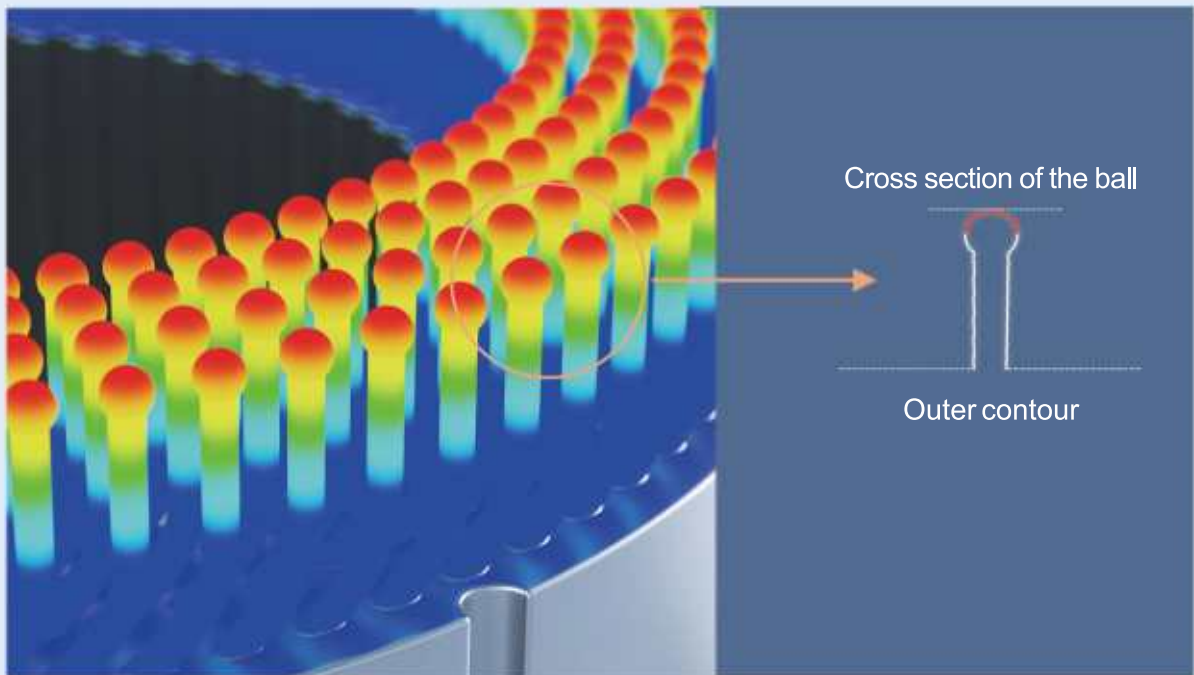
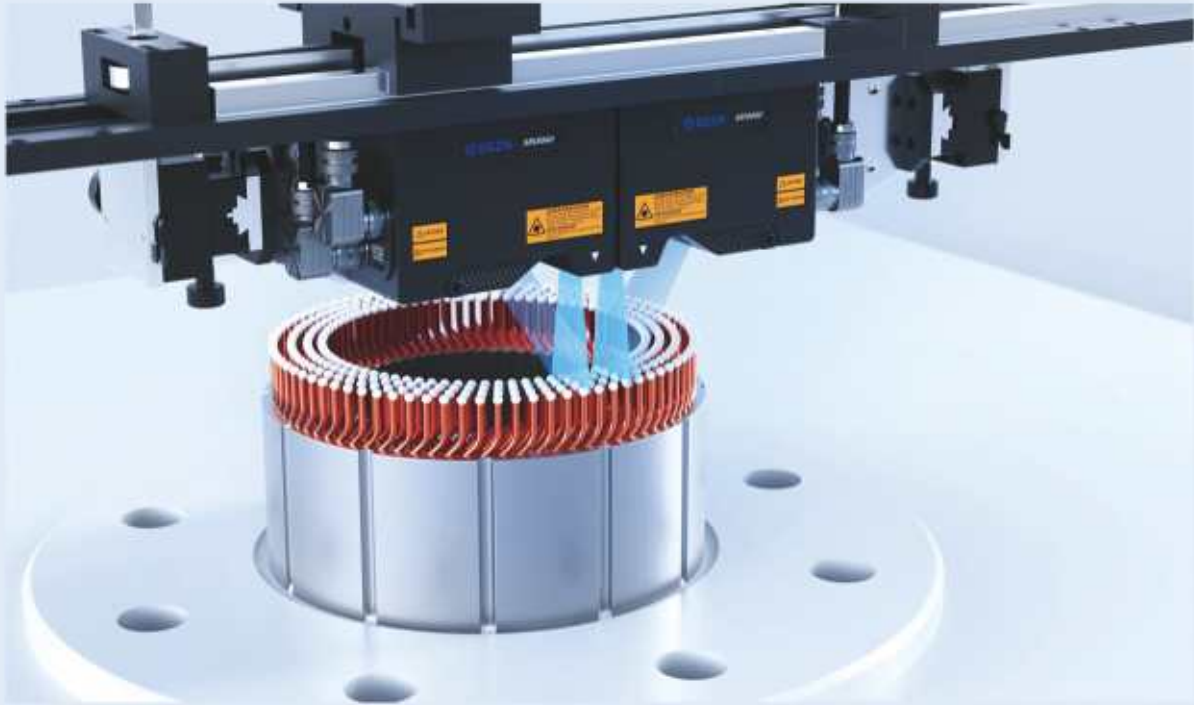

Connector Pin Detection

By head-to-head installing two 3D sensors and coordinating with a robotic arm for fast and precise positioning, it is possible to achieve blind spot free and real-time measurement of the gap width and segment difference of door seams, greatly improving detection efficiency compared to traditional detection methods.



Height difference
on both sides of the gap
0.090mm

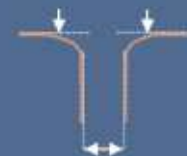

5.000mm
Measured value
of the width

Application Cases

Quality Inspection of Tires

By scanning with three large-field view 3D sensors, the scanned 3D point cloud data is concatenated to obtain complete 3D information of the tire, which can control the dynamic balance, contour, and angular eccentricity of the tire, as well as detect character and defects on the tire surface.

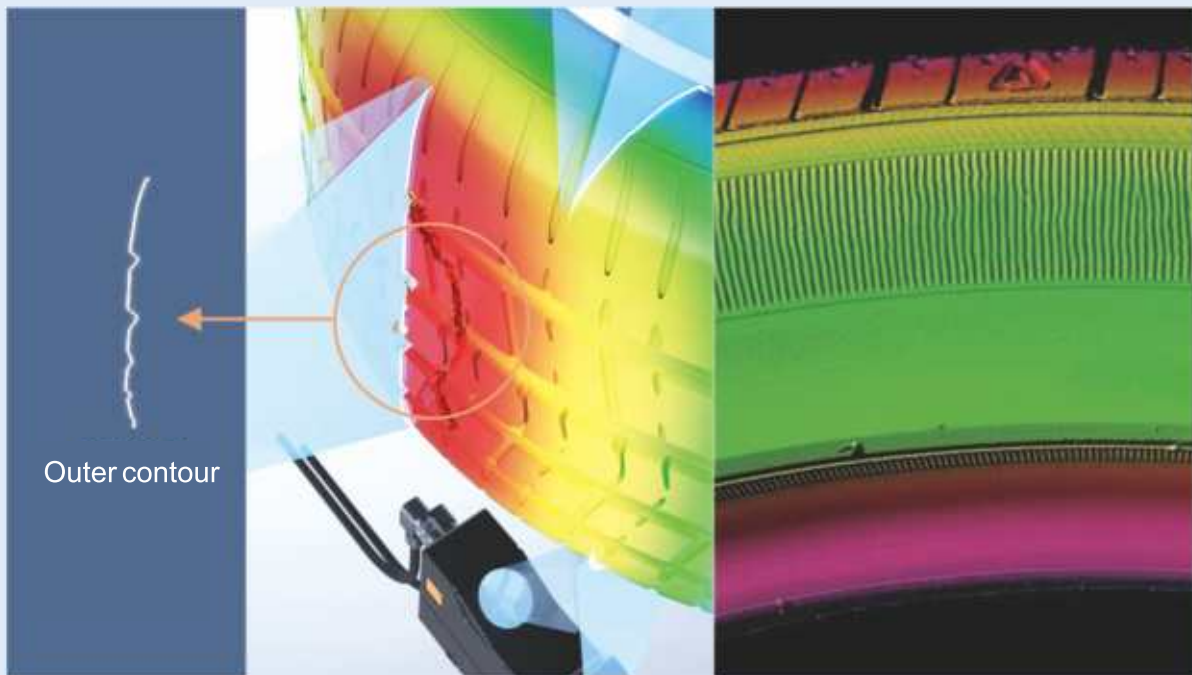

Track+Fastener Inspection

Use two 3D sensors to scan the left and right sides of the railway track respectively. The high-precision laser profiler has excellent outdoor anti-interference ability, accurately reproduces the three-dimensional images of the track and fasteners, and can detect rail wear, track spacing, fastener tightness, etc.



Application Cases

Silicon Wafer Overlapping Detection

The comprehensive and one-time inspection of the wafer lapping carrier, foreign debris and carrier deformation significantly improves the inspection efficiency and ensures the high-precision various inspection requirements.

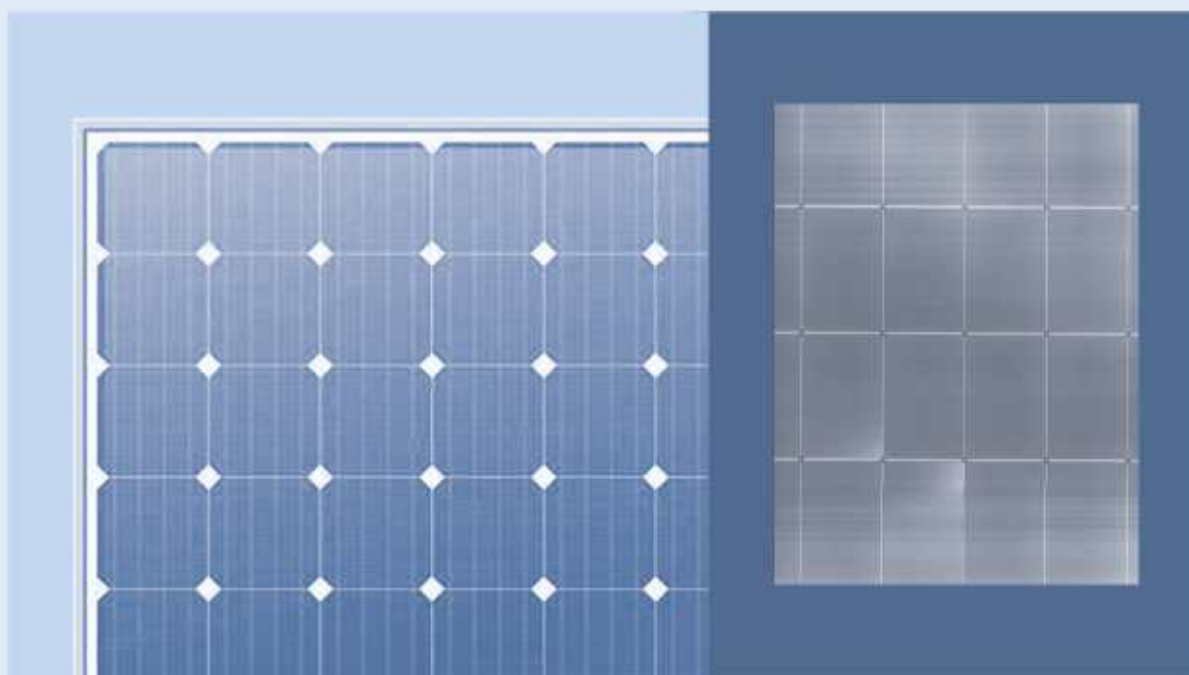

Silicon Rod Inspection

Four 3D sensors are installed on the same bracket, and each instrument is installed around the silicon rod in a 360° distribution, so as to construct an omni-directional scanning mode without blind areas. Through the spatial splicing technology, the three-dimensional data of silicon rods can be captured accurately in real time, including their size and radian changes, which ensures the consistency of silicon rods in the production process.



Product Parameters

SRI7000 series

Parameter / Model	SRI7050	SRI7060	SRI7120R	SRI7080	SRI7140
Reference distance ① (CD)	50mm	60mm	120mm	80mm	140mm
Z-axis height (f.s.)	16mm	33mm	27mm	42.5mm	88mm
Upper visual field height	7.5mm	13.5mm	12.5mm	18mm	34mm
Lower visual field height	8.5mm	19.5mm	14.5mm	24.5mm	54mm
X-axis width (near side)	26mm	34mm	41mm	51mm	70mm
Reference distance	28mm	40mm	46mm	58mm	86mm
X-axis width (remote site) ②	30mm	49mm	53mm	69mm	110mm
Light source wavelength	405nm	405nm	650nm	405nm	405nm
Laser grade	2M	2M	2M	2M	2M
Laser output power	10mW	10mW	10mW	10mW	10mW
Z-axis linearity	±0.02%F.S.	±0.02%F.S.	±0.02%F.S.	±0.02%F.S.	±0.02%F.S.
Z-axis repeatability ③	0.2μm	0.3μm	0.6μm	0.4μm	0.5μm
X-axis repeatability ④	2.5μm	4μm	4μm	5μm	7.5μm
X-axis data interval ⑤	10μm	15μm	16μm	20μm	30μm
X-axis contour points	3200				
Scanning speed (Hz)	1500~20000		2800~20000	1500~20000	
Input voltage (power)	DC 24V(45W)				
Dimension (mm)	165.5 x 54 x 94.5	150.5 x 54 x 94.5	136 x 54 x 118	155.5 x 54 x 94.5	155.5 x 54 x 94.5
Weight (g)	1100	1020	1000	1150	1000

Notes: ① The recommended optimal installation distance corresponds to the diffuse reflection mode for this parameter. ② The value under the condition of nominal or increased contour data interval. ③ The reference distance was obtained through 4096 average static tests. ④ The value under the condition of nominal contour data interval. ⑤ The nominal contour data interval.

Parameter / Model	SRI7240	SRI7400R	SRI7300	SRI7700	SRI71600
Reference distance ① (CD)	240mm	400mm	270mm	700mm	1070mm
Z-axis height (f.s.)	153mm	339mm	347mm	315mm	1530mm
Upper visual field height	59mm	115mm	102mm	140mm	380mm
Lower visual field height	94mm	224mm	245mm	175mm	1150mm
X-axis width (near side)	115mm	146mm	225mm	357mm	745mm
Reference distance	142mm	195mm	320mm	405mm	1120mm
X-axis width (remote site) ②	185mm	300mm	540mm	460mm	2250mm
Light source wavelength	405nm	660nm	450nm	450nm	450nm
Laser grade	2M	2M	3R	3R	3R
Laser output power	10mW	10mW	50mW	50mW	50mW
Z-axis linearity	±0.02%F.S.	±0.02%F.S.	±0.02%F.S.	±0.02%F.S.	±0.02%F.S.
Z-axis repeatability ③	1μm	5μm	8μm	10μm	100μm
X-axis repeatability ④	13μm	20μm	25μm	37.5μm	125μm
X-axis data interval ⑤	50μm	90μm	00μm	150μm	500μm
X-axis contour points	3200				
Scanning speed (Hz)	750~10000		1000~10000	750~10000	1250~10000
Input voltage (power)	DC 24V(45W)			DC 24V(60W)	
Dimension (mm)	200 x 54 x 100	200.5 x 54 x 94	218 x 67 x 116	600 x 58 x 86	294.5 x 59 x 102
Weight (g)	1200	1200	2000	3000	1850

Notes: ① The recommended optimal installation distance corresponds to the diffuse reflection mode for this parameter. ② The value under the condition of nominal or increased contour data interval. ③ The reference distance was obtained through 4096 average static tests. ④ The value under the condition of nominal contour data interval. ⑤ The nominal contour data interval.

SRI8000 series

Parameter / Model	SRI8020	SRI8060	SRI8065E	SRI8120
Reference distance (CD) ①	23mm	60mm	60mm	118mm
Z-axis height (f.s.)	5.2mm	18mm	14mm	68mm
Upper visual field height	2.3mm	8mm	6mm	29mm
Lower visual field height	2.9mm	10mm	8mm	39mm
X-axis width (near side)	13mm	26mm	18mm	70mm
Reference distance	14.5mm	31mm	20mm	84mm
X-axis width (remote site) ②	16.0mm	36mm	21mm	100mm
Light source wavelength	405nm	405nm	405nm	405nm
Laser grade	2M	2M	2M	2M
Laser output power	10mW	10mW	10mW	10mW
Z-axis linearity	±0.02%F.S.	±0.02%F.S.	±0.02%F.S.	±0.01%F.S.
Z-axis repeatability ③	0.1μm	0.2μm	0.12μm	0.45μm
X-axis repeatability ④	1.5μm	5μm	1.5μm	7.5μm
X-axis data interval ⑤	5μm	12μm	5.5μm	30μm
X-axis contour points	3200			
Scanning speed (Hz)	3200~60000		2300~60000	
Input voltage (power)	DC 24V(36W)			
Dimension (mm)	135.5 x 58 x 98	135.5 x 58 x 98	136 x 58 x 105	200x 54 x 94.5
Weight (g)	970	970	1200	1200

Notes: ① The recommended optimal installation distance corresponds to the diffuse reflection mode for this parameter. ② The value under the condition of nominal or increased contour data interval. ③ The reference distance was obtained through 4096 average static tests. ④ The value under the condition of nominal contour data interval. ⑤ The nominal contour data interval.

Parameter / Model	General parameters of products
Temperature characteristics	0.01%F.S./°C
Data interface	1 Ethernet interface 100Base-TX/1000Base-T
Input	Differential encoder (trigger), start signal
Working temperature	0~50°C
Storage temperature	-20~70°C
Working humidity	35%~85% No condensation
ESD Protection	Contact discharge 4kV, air discharge 8kV, comply with IEC 61000-4-2
EFT protection	Power port 2kV/5 or 100kHz, signal port 1kV/5 or 100kHz, comply with IEC61000-4-4
Shock resistance	Each axis 50Gs/3ms, comply with IEC 68-2-27 Ea
Vibration resistance	10Gs (10-500Hz), comply with IEC 68-2-6 Fc
Protection level	IP67, comply with IEC 60529

Product Parameters

		Cable Model of SRI Integrated 3D Laser Profiler			
IP Rating		IP67, comply with IEC 60529 ①			
Minimum cable bending radius (Fixed)		30mm			
Service life		The radius is not less than 72mm (100mm is recommended), and the number of repeated bends is > 10 million. ②			
Camera model		SRI7000/SRI8000			
Name		Network cable		I/O cable	
		L-shaped joint (For L-shaped assembly)	I-shaped joint (For straight-shaped assembly)	L-shaped joint (For L-shaped assembly)	I-shaped joint (For straight-shaped assembly)
General	3m	SCB-HNET-HR2Z-3m	SCB-HNET-HB2Z-3m	SCB-HO-HR2Z-3m	SCB-HIO-HB2Z-3m
	6m	SCB-HNET-HR2Z-6m	SCB-HNET-HB2Z-6m	SCB-HO-HR2Z-6m	SCB-HIO-HB2Z-6m
	10m	SCB-HNET-HR2Z-10m	SCB-HNET-HB2Z-10m	SCB-HO-HR2Z-10m	SCB-HIO-HB2Z-10m
Customized	20m	SCB-HNET-HR2Z-20m	/	SCB-HO-HR2Z-20m	/
Extended cable	5m	SCB-HNET-HR2YZ-5m	SCB-HNET-HB2Z-5m	SCB-HO-HR2YZ-5m	SCB-HIO-HB2Z-5m

Notes: ① The value when the sensor head is connected, ② Test environment: temperature 23°C, humidity 40%RH; Test conditions: cable carrier radius: 72mm; Measurement results: standard value > 30 million times; minimum value > 10 million times. Cable carrier working range: 1000mm, running speed: 60 round/minute.

Precautions for Using Cables

Please ensure that the minimum bending radius of the sensor head cable is above 30mm.

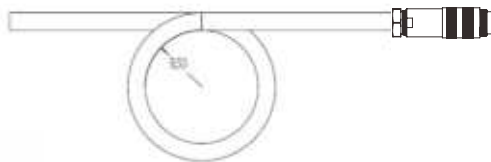

Minimum cable bending radius

When a splice is required, the splice head and the cable within 70mm of each end must be kept relatively fixed.

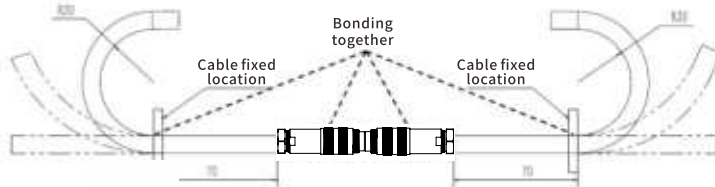

Cable splice connection

When using cable carriers, if not specifically specified, please choose products with R100 or higher.

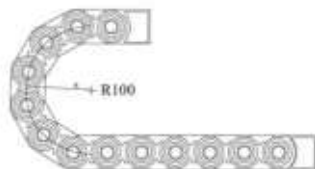

Minimum cable bending radius

Wiring Diagram of The System

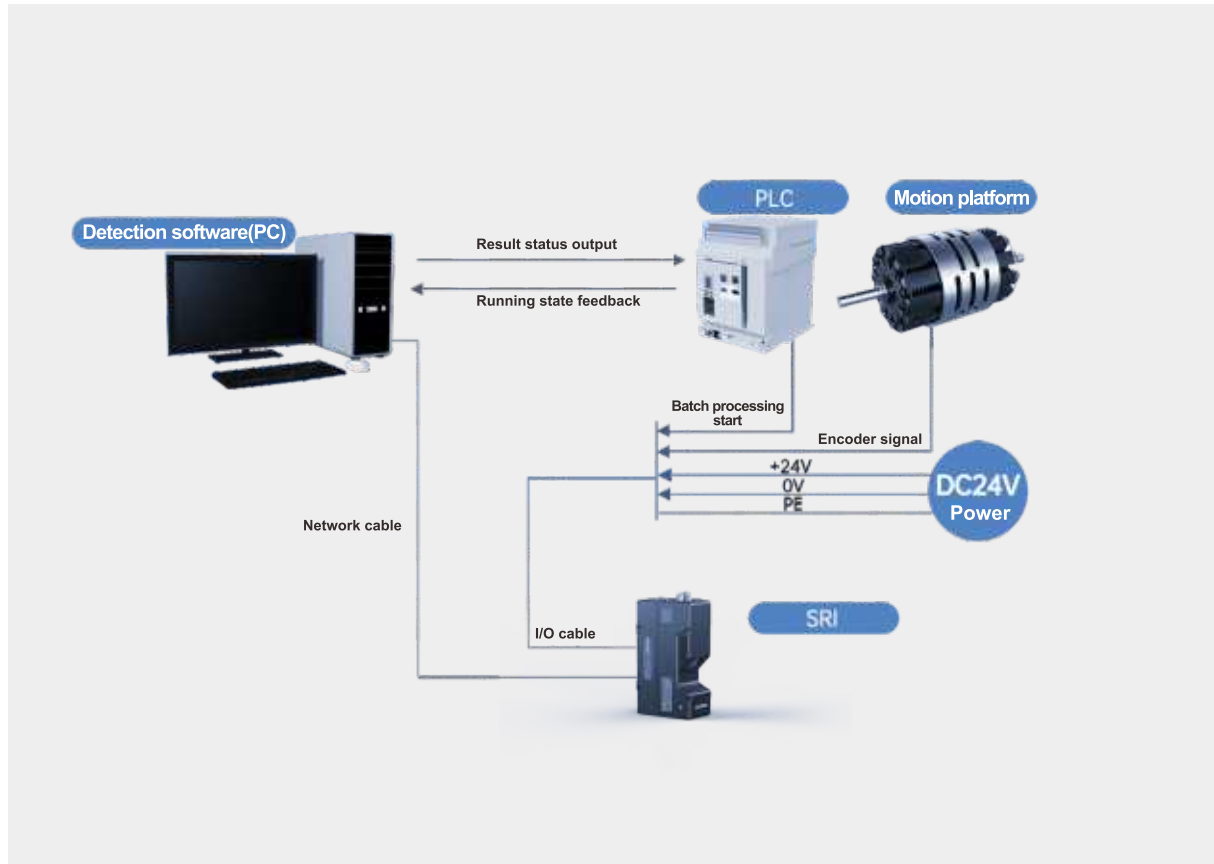

DIMENSIONS

Product Dimensions >

01

SRI7000 Series

02

SRI8000 Series

Product Dimensions

SRI7050

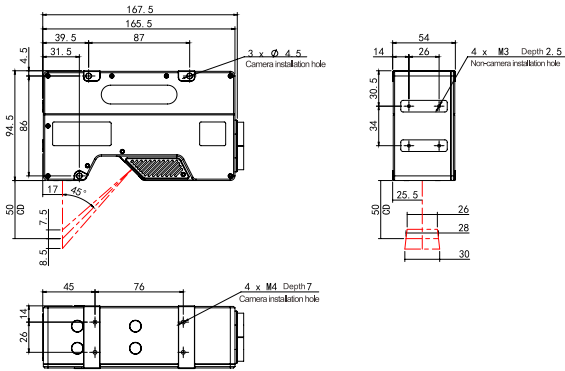

SRI7060

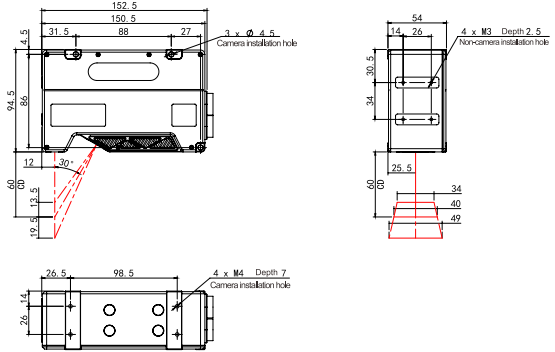

SRI7080

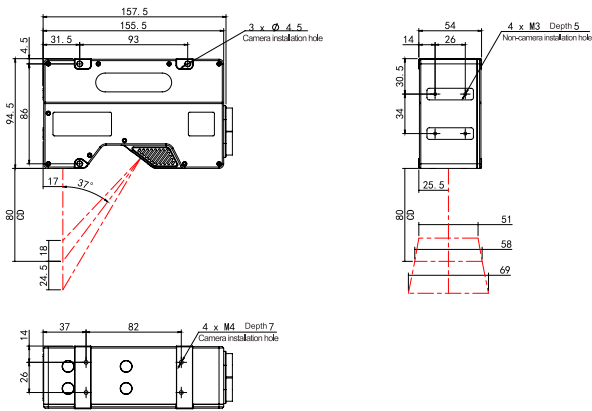

SRI7120R

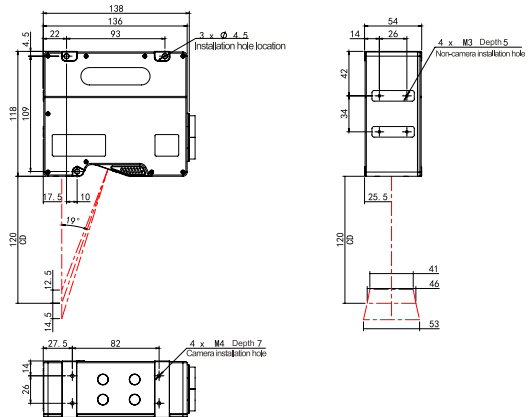

SRI7140

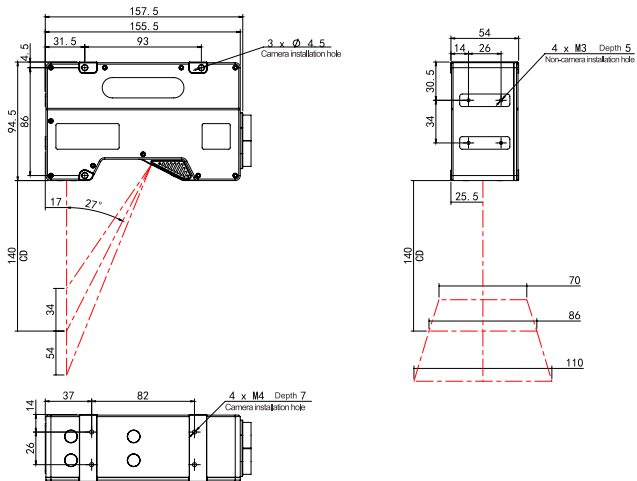

Product Dimensions

SRI7240

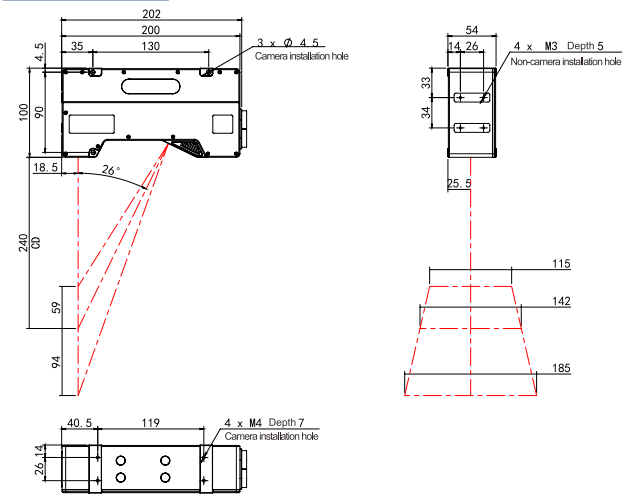

SRI7300

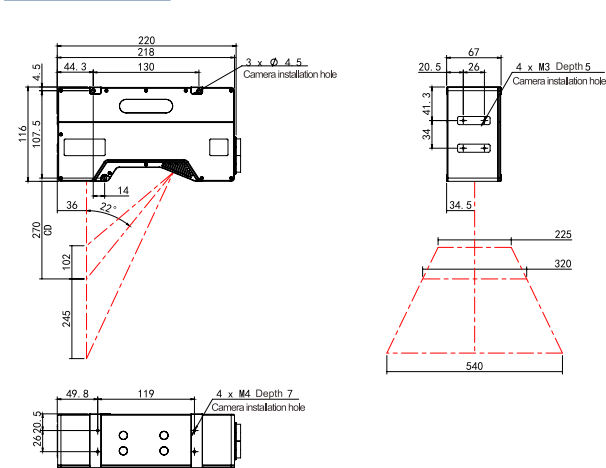

SRI7400R

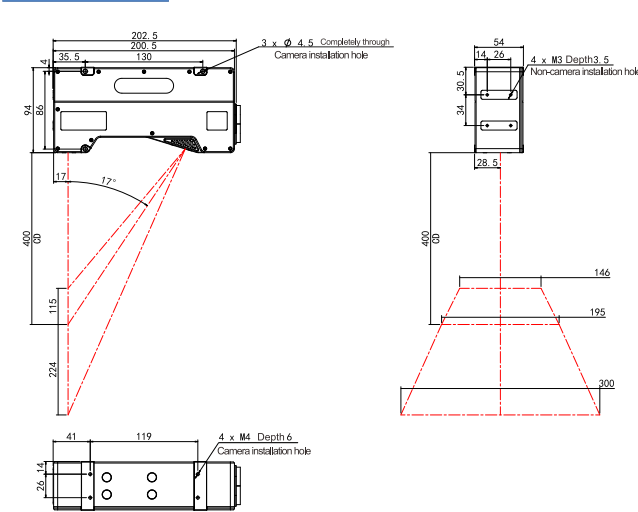

SRI71600

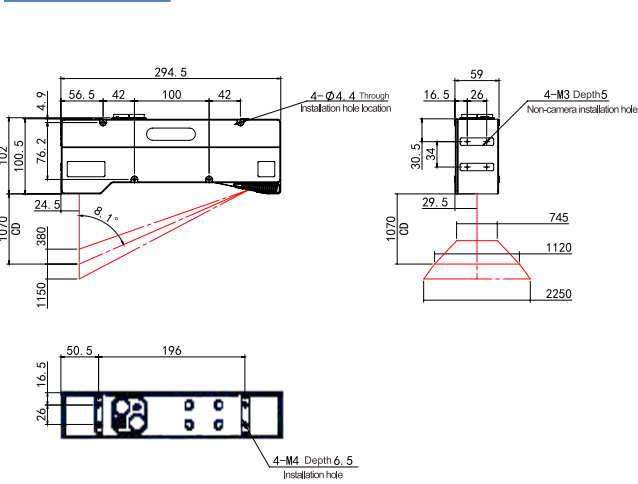

SRI7700

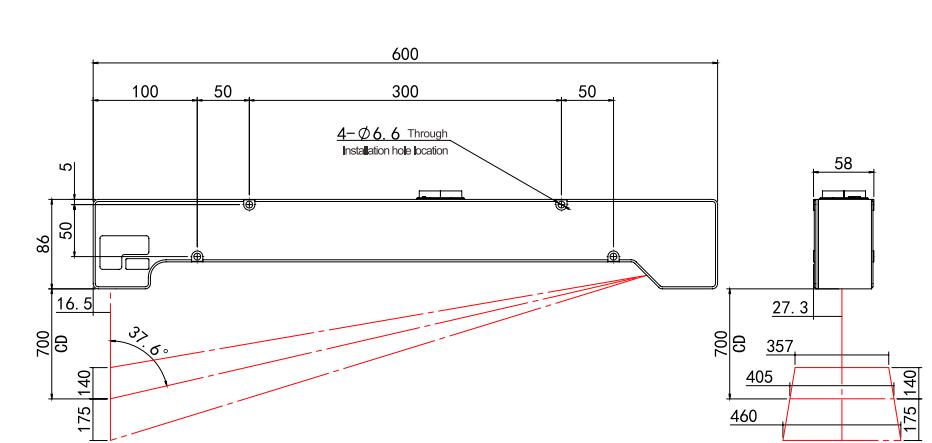

SRI8020

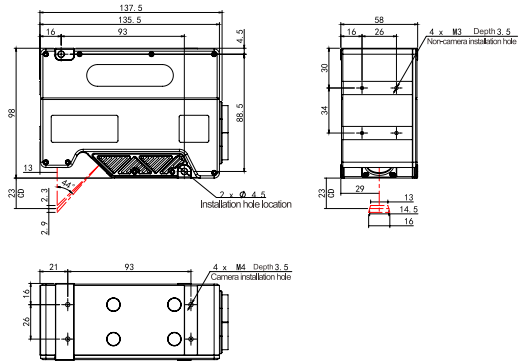

SRI8060

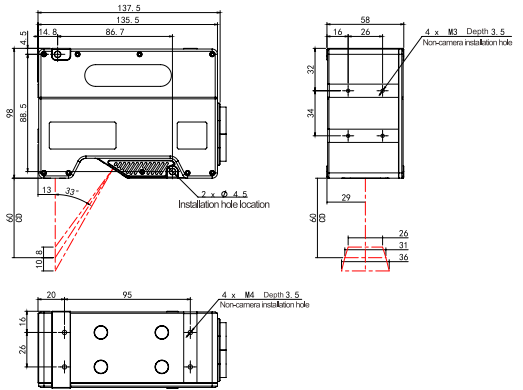

SRI8065E

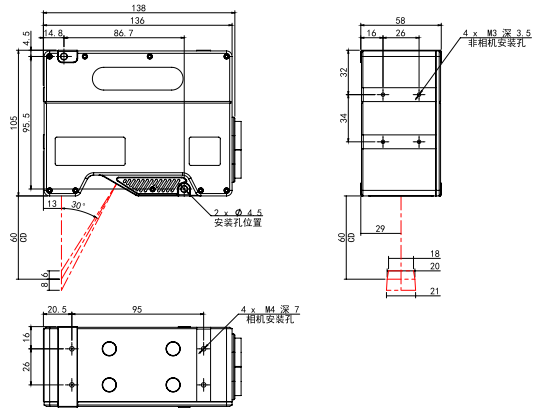

SRI8120

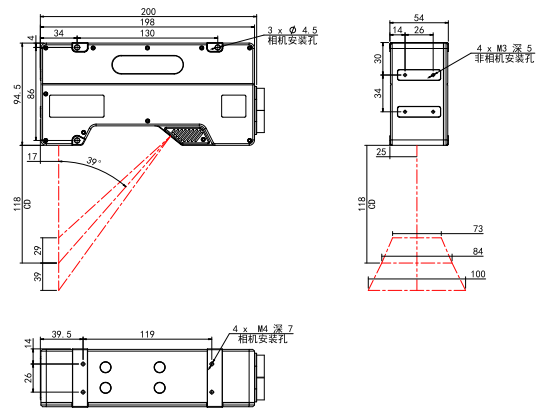

© Service covering:

China: Shenzhen, Suzhou (Kunshan), Shanghai, Wuxi, Beijing, Chengdu, Ningde, Taiwan, Wuhan, Xi'an, Hefei, Dongguan
Overseas: South Korea, Vietnam, Thailand, Malaysia, Singapore

SHENZHEN SINCEVISION TECHNOLOGY CO., LTD.

Headquarters:

5th Floor, Building 2, Chongwen Industrial Park, Nanshan Zhiyuan, Nanshan District, Shenzhen, China

Dongguan Office:

Room 407, Building F5, Tian'an Digital City, Nancheng District, Dongguan City, Guangdong Province, China

North China Office:

Room 808, Building 3, Jinmao Plaza, Auto Museum East Road, Fengtai District, Beijing, China

East China Office:

Room 1305, Building 7, Xiangyu Liang'an Trade Center, No.1588, Chuangye Road, Kunshan, Jiangsu Province, China

Southwest China Office:

Room 604, Block B, Yingchuang International Building, No. 66, Chuangzhi South 1st Road, Pidu District, Chengdu

Northwest China Office:

Room 601, Chuangke Building, Cuihua Road, Yanta District, Xi'an City, Shaanxi Province, China

Website: www.cnsszn.com Tel: 0755-29655425 400-966-0626



SinceVision's
Linked in Account



SinceVision's
YouTube Account

The product information and images in this brochure are for reference only. As the products are constantly updated, please refer to the actual products. SinceVision reserves the right of final interpretation and revision of this brochure.