

Aries 16

The Aries 16 is a new generation of BSI sCMOS camera developed exclusively by Tucsen Photonics. With sensitivity which matches EMCCD and surpasses binned sCMOS combined with high full well capacity normally observed in large format CCD cameras, the Aries 16 provides a fantastic solution for both low-light detection and high-dynamic range imaging.



Key Features	Benefits
BSI –sCMOS Technology	16 μm large pixels, 0.9 e ⁻ readout noise, and up to 90% QE. ^[1]
Advanced Cooling Technology	To reduce the thermal noise, ensuring high SNR imaging and stable measurement results.
74 ke ⁻ Well Capacity	High dynamic range to capture strong and weak signals simultaneously.
HDR & Low Noise Modes	Double modes provide flexibility for high dynamic and low-light applications

Typical Applications

- Cold Atoms
- Quantum Physics
- Single Molecule Fluorescence Detection
- Super Resolution
- FRET
- FCS
- TIRF
- Bioluminescence
- Chemiluminescence

Noted Examples

[1]Aries 16 can replace EMCCD in extreme signal detection fields such as Bioluminescence, and the imaging quality is equivalent.

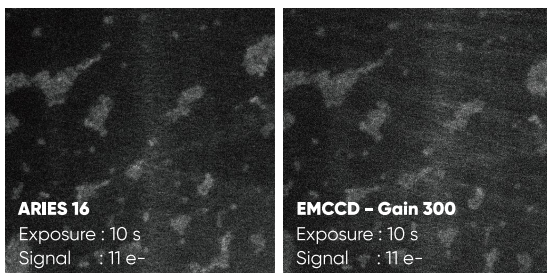

Quantum Efficiency

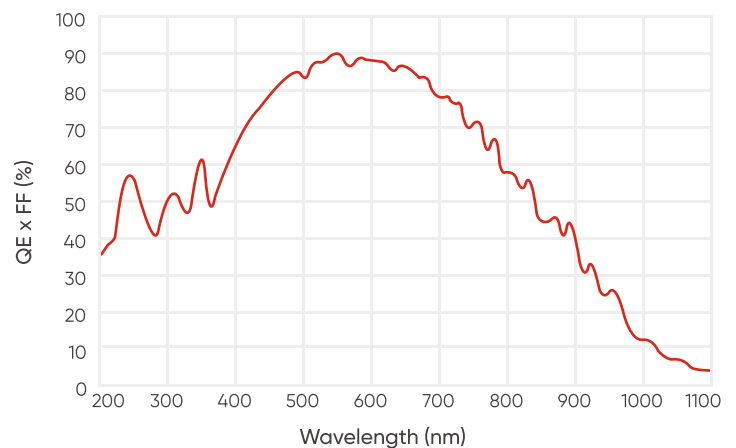

Dimensions (Unit: mm)

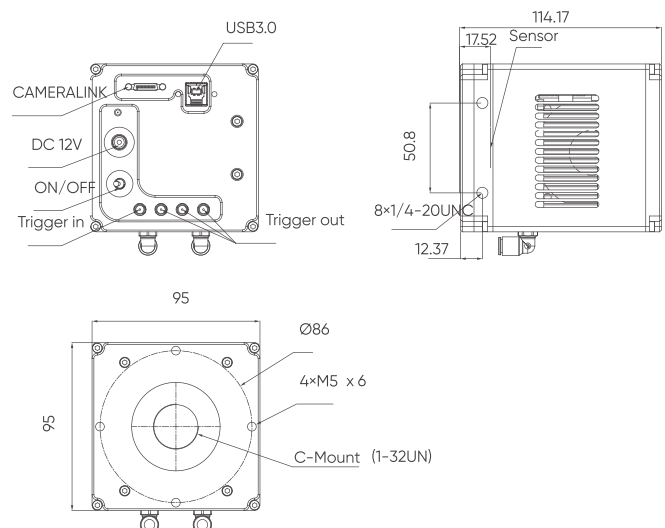

Specifications

Ultimate Sensitivity sCMOS Camera

www.tucsen.com

Model	Aries 16
Color/Mono	Mono
Peak QE	90.7% @ 550 nm
Resolution	800 (H) × 600 (V)
Array Diagonal	16 mm
Pixel Size	16 μm × 16 μm
Effective area	12.8 mm × 9.6 mm
Full well capacity	Typ.: 73 ke-
Dynamic Range	Typ.: 94.8 dB
Readout Rate	60 fps @ HDR mode, 25 fps @ Low noise mode
Readout Noise	Typ. : 1.6 e- @ HDR mode, 0.9 e- @ Low noise mode
Shutter Mode	Rolling / Global reset
Exposure Time	26 μs ~ 60 s
DSNU	0.3 e-
PRNU	0.3 %
Cooling Method	Air, Liquid
Cooling Temperature	Air: 50 °C below ambient, Liquid: 60 °C below ambient
Dark current	0.2 e- / pixel / s
Binning	2 × 2, 4 × 4, Free binning
ROI	Support
Trigger Mode	Hardware, Software
Output Trigger Signals	Exposure start, Global, Readout end, High level, Low level
Trigger Interface	SMA
Timestamp	Support
Data Interface	USB 3.0 & CameraLink
SDK	C, C++, C#, Python
Bit Depth	12 bit & 16 bit
Optical Interface	C-mount
Power	12 V / 8 A
Power Consumption	~ 38 W
Dimensions	95 mm × 95 mm × 114 mm
Weight	1500 g
Software	Mosaic 3.0, SamplePro, LabVIEW, MATLAB, Micro-Manager 2.0
Operating System	Windows
Operating Environment	Working: Temp. 0~40 °C, HUM 0~85% Storage: Temp. 0~60 °C, HUM 0~90%